

CONSTRUCTION DETAIL NO. 25

STANDARD FEATURES:

- AUTO-LOCK T-316 STAINLESS STEEL HOLD OPEN ARM WITH RELEASE HANDLE
- T-316 STAINLESS STEEL HINGES AND ATTACHING HARDWARE
- T-316 STAINLESS STEEL SLAM LOCK WITH REMOVABLE KEY
- STAINLESS STEEL COMPRESSION SPRING ASSIST
- BUILT-IN NEOPRENE CUSHION/GASKET
- NON-OZONE DEPLETING BITUMINOUS COATING
- DOUBLE LEAF CONSTRUCTION
- 300 LBS. PER SQ. FT. LOAD RATING (1464 KG. PER SQ. METER LOAD RATING)
- EXTRUDED ALUMINUM FRAME
- RECESSED LIFTING HANDLE
- ALUMINUM FALL-PROTECTION GRATING
- LIFETIME GUARANTEE
- AS MANUFACTURED BY HALLIDAY, BILCO, US FOUNDRY, OR APPROVED EQUAL.

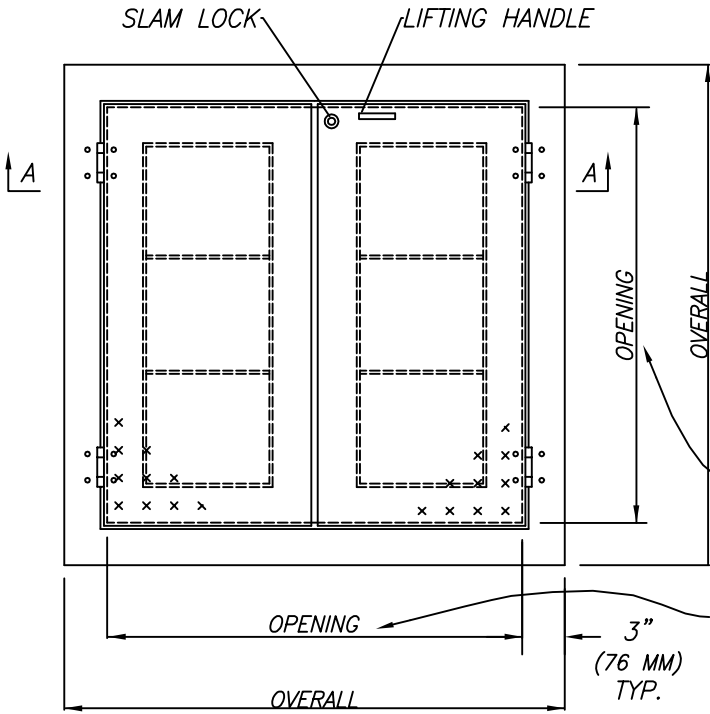

HATCH AND OPENING DIMENSIONS TO BE SUBMITTED TO SSSD FOR APPROVAL

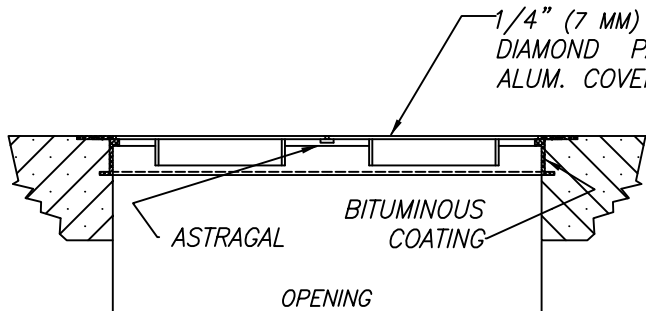

SECTION A-A

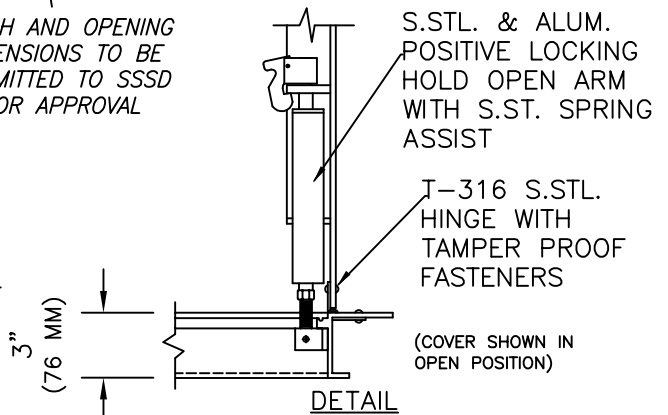
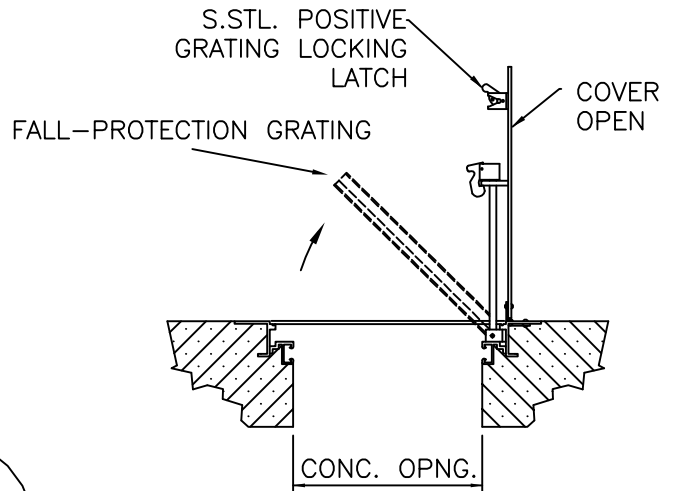
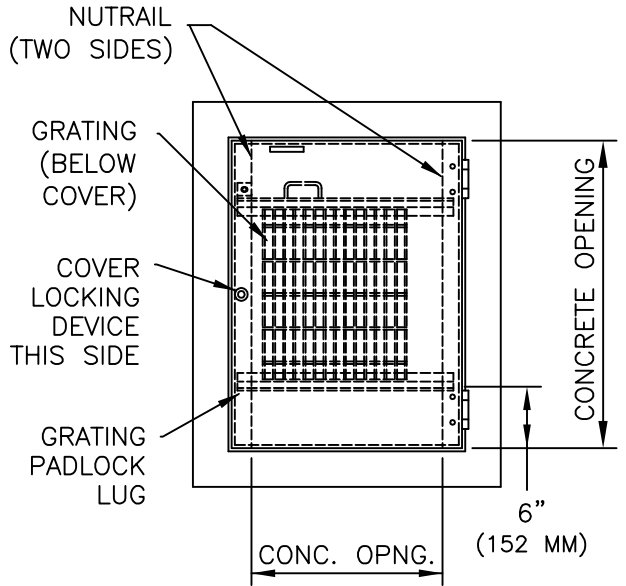

HATCH WITH FALL-PROTECTION GRATING

SCALE: NONE

REVISION DATE: APRIL 13, 2009