

CONSTRUCTION DETAIL NO. 4

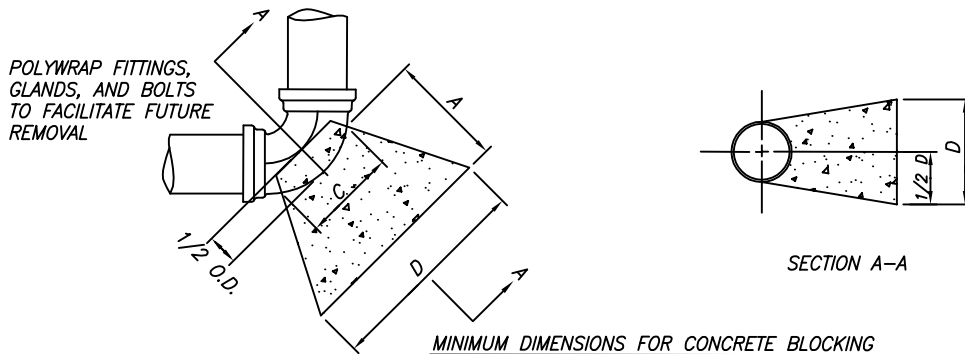

MINIMUM DIMENSIONS FOR CONCRETE BLOCKING

BEND	SIZE	VOLUME				CY
		A	B	C	D	
11 1/4°	6"	1'-0"	2'-0"	4"	1'-0"	0.05
	8"	1'-0"	2'-0"	5"	1'-0"	0.05
	12"	1'-0"	2'-0"	7"	1'-0"	0.05
	16"	1'-0"	2'-0"	1'-0"	2'-0"	0.22
	20"	2'-0"	3'-0"	1'-3"	2'-0"	0.32
22 1/2°	6"	1'-0"	2'-0"	6"	1'-0"	0.05
	8"	1'-0"	2'-0"	7"	1'-0"	0.05
	12"	1'-0"	2'-0"	10"	2'-0"	0.11
	16"	2'-0"	4'-0"	1'-0"	2'-0"	0.37
	20"	2'-0"	4'-0"	1'-3"	3'-0"	0.58
45°	6"	1'-0"	2'-0"	6"	1'-0"	0.05
	8"	1'-0"	2'-0"	7"	2'-0"	0.10
	12"	2'-0"	3'-0"	11"	3'-0"	0.44
	16"	3'-0"	5'-0"	1'-0"	3'-0"	1.00
	20"	4'-0"	6'-0"	1'-3"	4'-0"	2.15
90°	6"	1'-0"	2'-0"	1'-0"	2'-0"	0.11
	8"	2'-0"	3'-0"	1'-2"	2'-6"	0.37
	12"	2'-0"	4'-0"	2'-0"	4'-0"	0.84
	16"	4'-0"	6'-0"	2'-2"	4'-9"	2.84
	20"	4'-0"	7'-0"	2'-8"	6'-4"	4.51
TEES & PLUGS	6"	1'-0"	2'-0"	10"	1'-6"	0.08
	8"	1'-9"	2'-6"	1'-1"	2'-0"	0.23
	12"	2'-6"	3'-9"	1'-7"	3'-0"	0.75
	16"	3'-0"	5'-0"	2'-2"	4'-0"	1.59
	20"	4'-0"	6'-0"	2'-8"	5'-0"	3.21

FOR 3" & 4" PIPE, USE 6" SIZES

DESIGN DATA:

- DIMENSIONS OF THRUST BLOCK IN FEET BASED ON 2000 POUNDS PER SQUARE FOOT SOIL BEARING PRESSURE AND 200 POUNDS PER SQUARE INCH TEST PRESSURE. ACTUAL INSIDE DIAMETER OF DUCTILE IRON PIPE, CLASS 51 USED AS STANDARD.
- CONCRETE SHALL HAVE A COMPRESSIVE STRENGTH OF 3000 P.S.I. AT 28 DAYS. HIGH EARLY CONCRETE SHALL BE USED.

NOTE

SOIL CONDITIONS SHALL BE VERIFIED BY THE S.S.S.D. INSPECTOR BEFORE DESIGN IS IMPLEMENTED.



CONCRETE THRUST BLOCK DETAIL

SCALE: NONE

REVISION DATE: APRIL 13, 2009