

# CONSTRUCTION DETAIL NO. 23

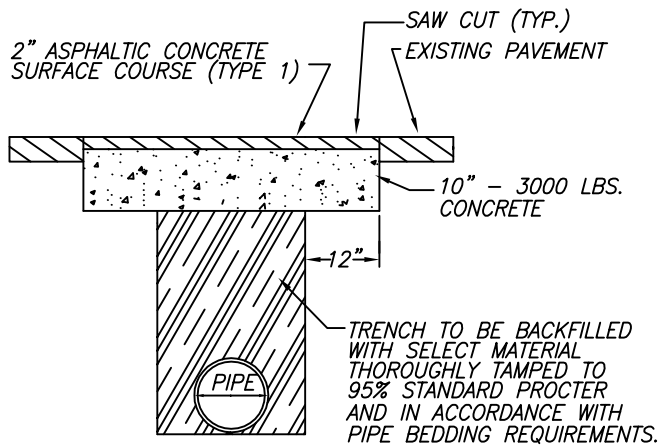

HIGH VOLUME

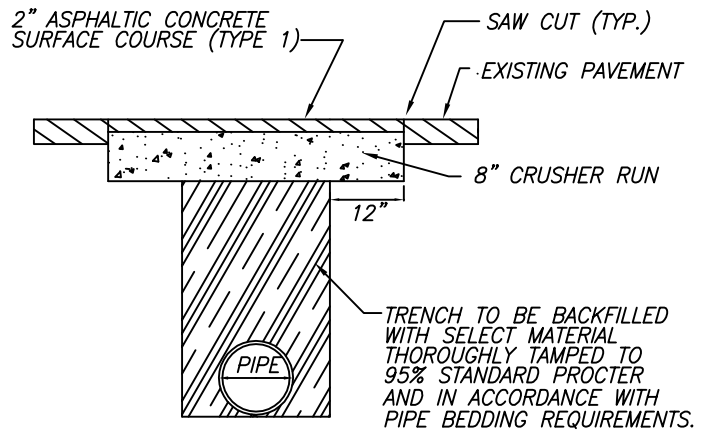

LOW VOLUME

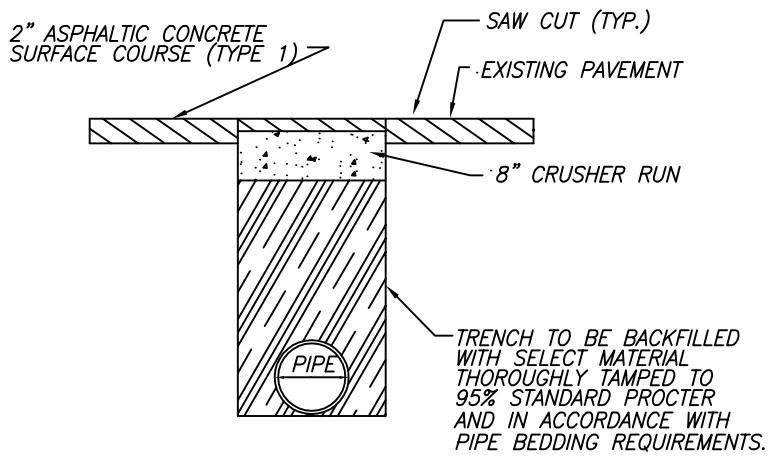

DRIVEWAYS

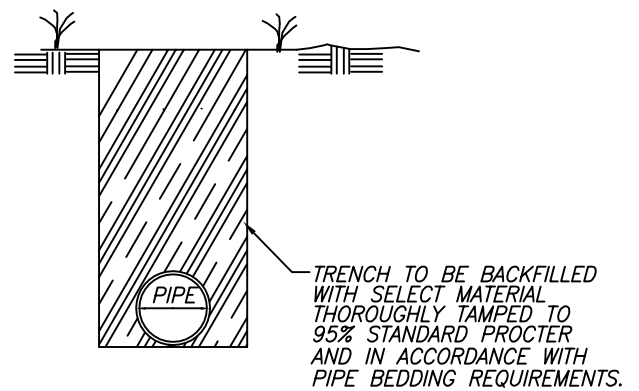

TYPICAL TRENCH



## TYPICAL PAVEMENT REPAIR DETAILS

SCALE: NONE

REVISION DATE: APRIL 13, 2009